

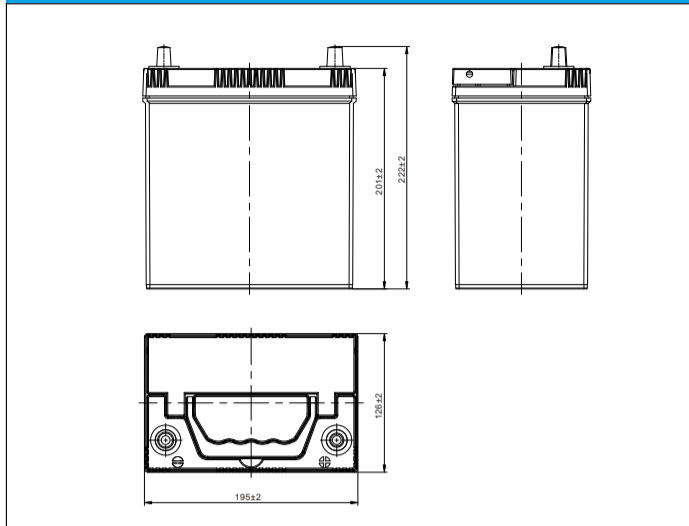

**LEOCH BATTERY**  
**EFB B20 (12V40Ah)**



**Dimensions (mm)**



**Physical Specification**

Nominal Voltage		12V
Nominal Capacity(20HR)		40Ah
Dimension	Length	195±2mm(7.68inches)
	Width	126±2mm(4.96inches)
	Container Height	201±2mm(7.91inches)
	Total Height(with Terminal)	222±2mm(8.74inches)
Wet Weight		Approx 10.7Kg(23.59lbs)
Standard Terminal		3
Cell layout		0
Hold-Down		B0
Cell plate qty		/
Case		Black-PP Material
Cover		Black-PP Material
Handle		/

**Electrical Specification**

Rated Capacity	20 hour rate(2.0A)	40Ah
Reserve Capacity		60min
Cold Cranking Performance Amps@0°F(-18°C)		390A

**Standard Terminal (mm)**

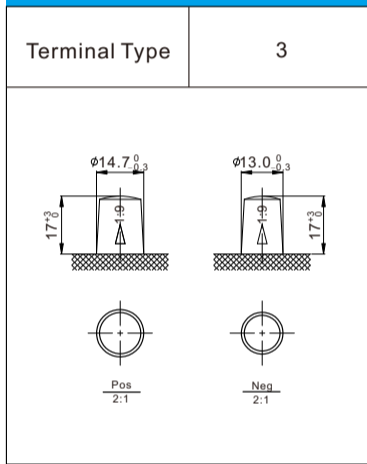

**Cell Layout**

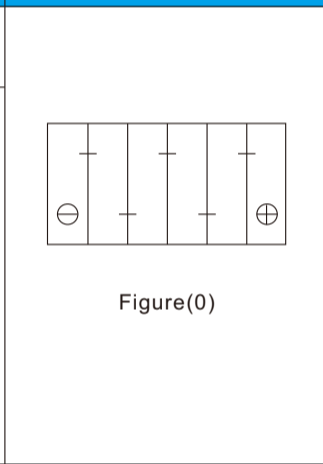

**Discharge Characteristics(-18°C,0°F)**

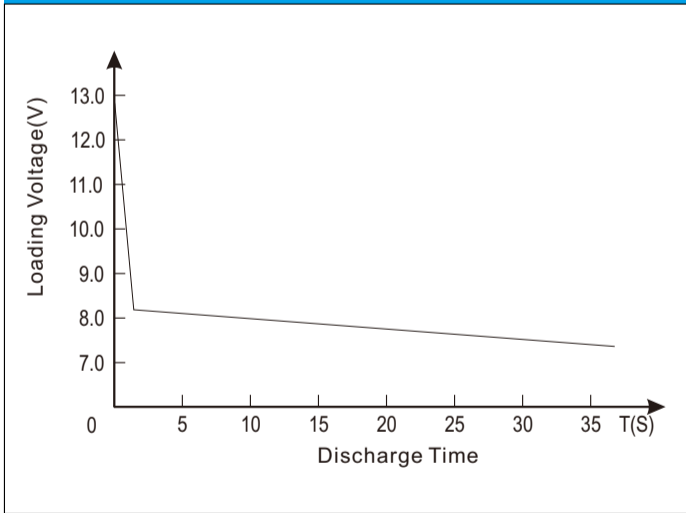

**Discharge Characteristics(25°C,70°F)**

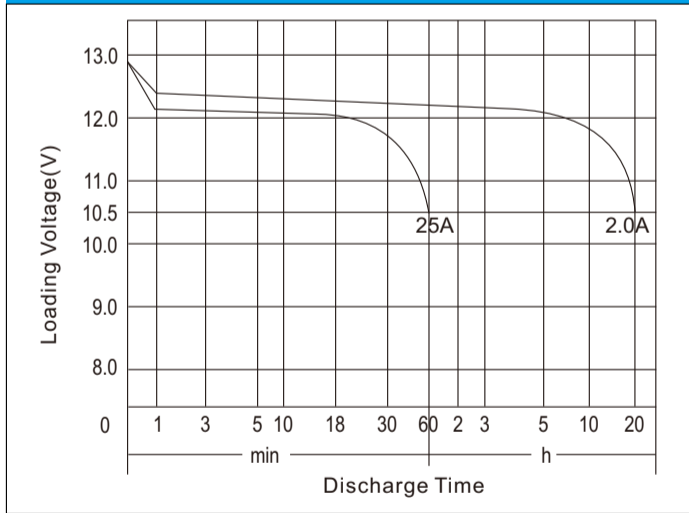

**50% DOD Cycle Life Characteristics**

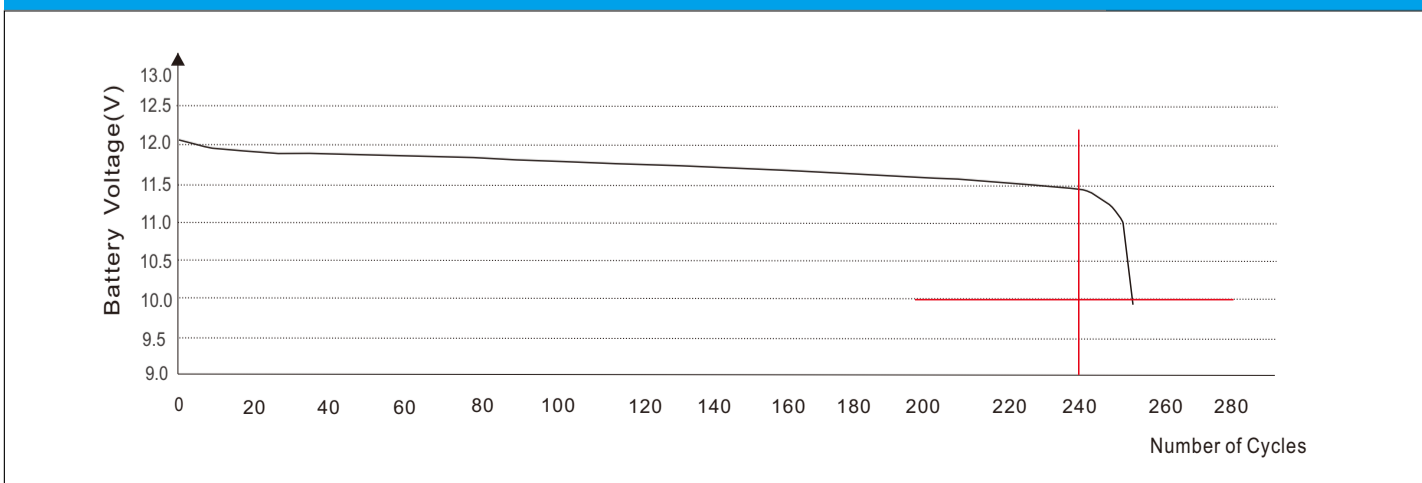

\*Values are subject to variation of +/- 5% in normal manufacturing processes.  
\*Technical specifications and the product line above could be changed without prior notice.